

Łańcuchy tulejkowe
Bushing chains
PN-78/M-84167, DIN 8164
Odmiana A
Variety A

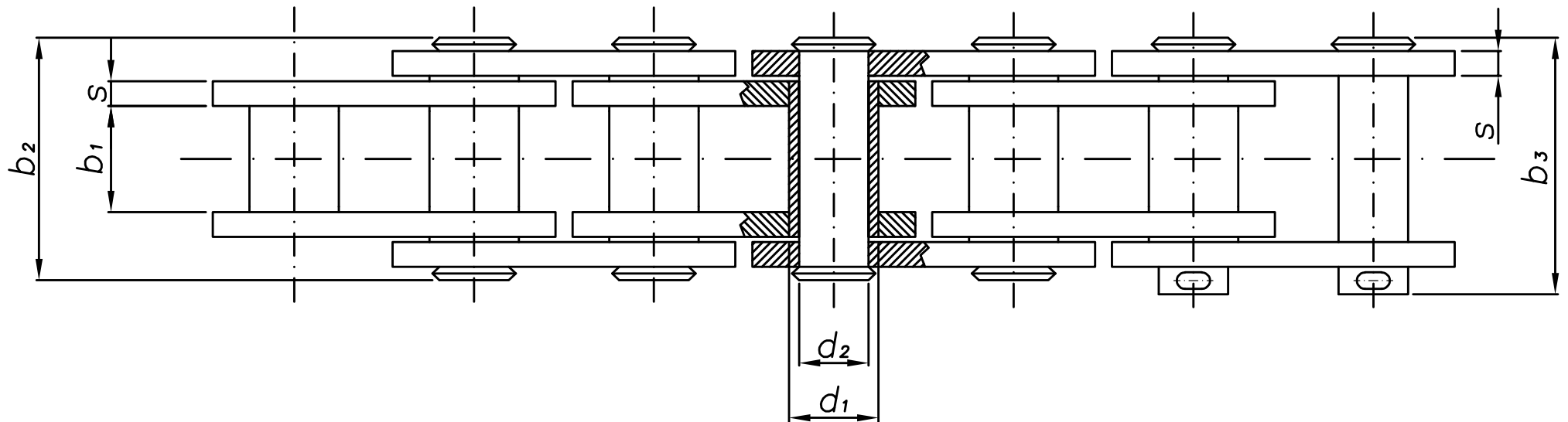
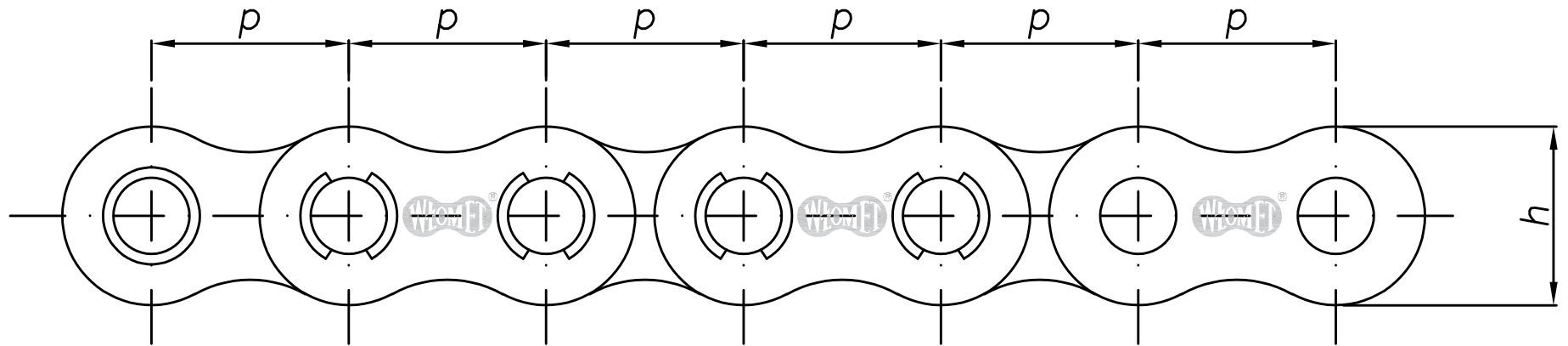

Łańcuchy tulejkowe

Bushing chains

PN-78/M -84176, DIN 8164

Odmiana A

Variety A

ISO Nr.	p	d ₁ max	d ₂ max	b ₁ min	b ₂ max	b ₃ max	h max	s max	F min	Q
	mm	mm	mm	mm	mm	mm	mm	mm	kN	kg/m
1	2	3	4	5	6	7	8	9	10	11
Łańcuchy precyzyjne o podziałce calowej										
04 C	6,35	3,30	2,31	3,18	9,10	11,60	6,02	0,80	3,50	0,13
06 C	9,525	5,08	3,58	4,77	13,20	16,50	9,05	1,35	7,90	0,34
Łańcuchy precyzyjne o podziałce metrycznej										
20 M	20,00	12,00	8,00	16,00	34,00	37,00	19,00	3,00	30,00	2,14
25 M	25,00	15,00	10,00	18,00	36,00	40,00	24,00	3,00	40,00	2,78
30 M	30,00	17,00	11,00	20,00	43,00	47,00	28,00	4,00	65,00	4,00
35 M	35,00	18,00	12,00	22,00	46,00	49,00	30,00	4,00	75,00	4,30
40 M	40,00	20,00	14,00	25,00	53,00	58,00	35,00	5,00	100,00	6,55
45 M	45,00	22,00	16,00	30,00	62,00	67,00	40,00	6,00	140,00	7,80
50 M	50,00	26,00	18,00	35,00	68,00	72,00	44,00	6,00	170,00	8,80
55 M	55,00	30,00	20,00	45,00	86,00	93,50	48,00	8,00	200,00	10,36
60 M	60,00	32,00	22,00	50,00	90,50	98,00	58,00	8,00	250,00	15,20
65 M	65,00	36,00	26,00	55,00	98,00	106,00	60,00	10,00	300,00	18,60

F – obciążenie zrywające (min.)

Q – masa 1 mb łańcucha

F – breaking load (min.)

Q – weight kg/m